



Barcode: 5060452080451

# mobile tuffbench™

Product code: MBH12

- » Ideal workbench for many applications.
- » Customise it easily by attaching vices etc to the wooden surface.
- » Integral secure cabinet to lock away tools and equipment.



Watch the Mobile TuffBench in action

## Product features



2x 5-lever deadlock



No detachable parts



Heavy-duty 6" castors



Forklift skids



Working load limit



Suitable for site

## Product specifications

Weight	96kg
Colour	Black grey: RAL 7021
Finished coating	Powder coated
Material & thickness	2mm and 3mm steel
Quantity of keys	2 keys
Does it have storage	Yes
How are castors fitted?	Quick-fix bolt on heavy-duty castor kit

## Dimensions - External dimensions includes protrusions

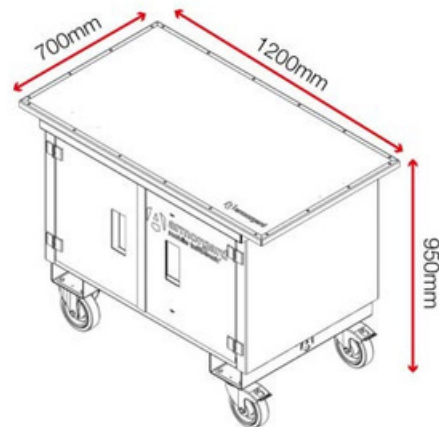

## Optional extras - Contact Armorgard to find out more



Engineers vice CV6



Chain vice CV4

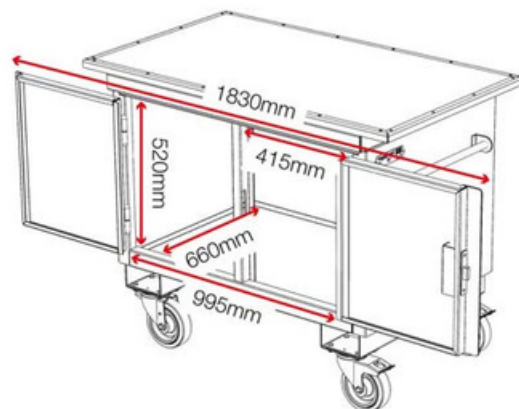

Disclaimer: all dimensions and weights are approximate